

CITY OF NEWTON, ILLINOIS

ORDINANCE NO. 2024-08

**AN ORDINANCE AMENDING THE
REVISED CODE OF ORDINANCES
FOR THE
CITY OF NEWTON, ILLINOIS**

**ADOPTED BY THE
CITY COUNCIL
OF THE
CITY OF NEWTON, ILLINOIS**

THIS 21ST DAY OF MAY, 2024

**Published in pamphlet form by authority of the City Council of the City of
Newton, Jasper County, Illinois this 21st day of May, 2024.**

ORDINANCE NO. 2024-08

AN ORDINANCE AMENDING CHAPTERS 11 AND 33 OF THE REVISED CODE OF ORDINANCES FOR THE CITY OF NEWTON, JASPER COUNTY, ILLINOIS.

WHEREAS, the City of Newton, Illinois is an Illinois non-home rule municipal corporation pursuant to Article VII, § 8 of the 1970 Illinois Constitution, organized and operating under the Illinois Municipal Code, 65 ILCS 5/1-1-1, *et seq.*; and

WHEREAS, the corporate authorities of each municipality may pass all ordinances and make all rules and regulations proper and necessary, to carry into effect the powers granted to municipalities, with such fines or penalties as may be deemed proper, 65 ILCS 5/1-2-1; and

BE IT ORDAINED BY THE CITY COUNCIL OF THE CITY OF NEWTON, JASPER COUNTY, ILLINOIS, THAT:

SECTION 1: Amendment. The following exhibits shall amend **"The Revised Code of Ordinances"** of the City of Newton, Jasper County, Illinois and shall be as follows:

SEE EXHIBITS "A" & "B" FOLLOWING

SECTION 2: Severability of Provisions. Each section, paragraph, sentence, clause and provision of this Ordinance is severable, and if any provision is held unconstitutional or invalid for any reason, such decision shall not affect the remainder of the Ordinance, nor any part thereof, other than that part affected by such decision.

SECTION 3: Conflicting Ordinances. Any conflicting ordinances, code provisions or pertinent portions thereof in effect at the time this ordinance takes effect are hereby repealed.

SECTION 4: Effective. This Ordinance shall be in full force and effect from and after its passage, approval, and publication in pamphlet form as provided by law.

SECTION 5: Passed this 21st day of May, 2024 by the City Council of the City of Newton, Jasper County, Illinois, and deposited and filed in the office of the City Clerk in said City on that date.

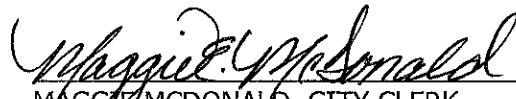

MAGGIE MCDONALD, CITY CLERK
NEWTON, ILLINOIS

NAME	AYE	NAY	ABSTAIN	ABSENT	CONFLICT
Gayle Glumac	✓				
Kaleb Wright	✓				
Larry Brooks	✓				
R.J. Lindemann III	✓				
Eric Blake	✓				
Mike Swick	✓				
Josh Kuhl, Mayor					

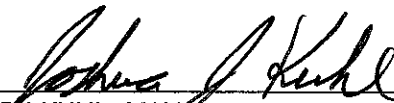
Approved by the Mayor of the City of Newton, Jasper County, Illinois, this 21st day of May, 2024.



JOSH KUHL, MAYOR
NEWTON, ILLINOIS

ATTEST:

MAGGIE MCDONALD, CITY CLERK
NEWTON, ILLINOIS

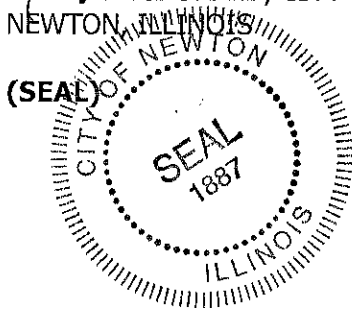

CITY CLERK'S CERTIFICATE

STATE OF ILLINOIS)
COUNTY OF JASPER) ss. CITY CLERK'S OFFICE
CITY OF NEWTON)

I, Maggie McDonald, City Clerk of the City of Newton, Illinois, do hereby certify that the following Ordinance of the City of Newton, Jasper County, Illinois, published by authority of the City Council was duly passed by the City Council of the City of Newton, Illinois, approved by the Mayor, and published in pamphlet form according to law on this date, and that this ordinance is a true and perfect copy of the ordinance, as passed, approved, and now of record and on file in my office as provided by law.

In witness whereof, I have set my hand and affixed the Corporate Seal of the City of Newton, Illinois, this 21st day of May, 2024.

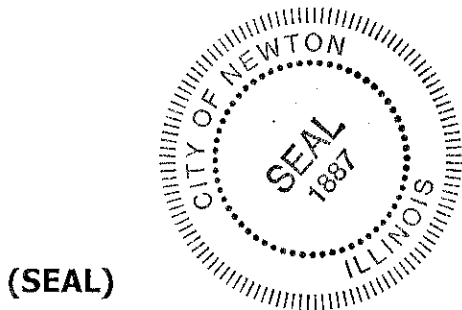

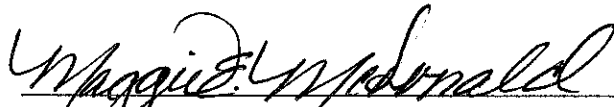

MAGGIE MCDONALD
CITY CLERK
NEWTON, ILLINOIS

EXHIBIT "A"

CHAPTER 11

ELECTRIC SYSTEM

ARTICLE I – GENERALLY

11-1-1 **SERVICE CHARGES.** There are hereby established rates and charges for the use and service of electric current for light and power based upon electricity consumed as recorded by electric meters based upon the type of premises served as follows:

(A) **Electricity Used For Residential Purposes.** (Available to single-family dwelling units for all domestic use.)

For the first 45 KWH used per month at \$0.238166 per KWH
For the next 80 KWH used per month at \$0.176014 per KWH
For all over 120 KWH used per month at \$0.137823 per KWH

The minimum charge for electric service used for residential purposes shall be **Ten Dollars Seventy-Two Cents (\$10.72)** per month for the first **forty-five (45) KWH**.

(B) **Electricity Used For Commercial Purposes.** (Available to commercial and non-residential customers for lighting and all power purposes.)

For the first 115 KWH used per month at \$0.280071 per KWH
For the next 135 KWH used per month at \$0.215316 per KWH
For the next 250 KWH used per month at \$0.184050 per KWH
For the next 500 KWH used per month at \$0.166181 per KWH
For all over 1,000 KWH used per month at \$0.131350 per KWH

The minimum charge for electricity used for commercial purposes shall be **Thirty-Two Dollars Twenty-One Cents (\$32.21)** per month for the first **one hundred fifteen (115) KWH**.

These rates will be effective **June 1, 2024**.

(C) **Rates and Charges for Electric System.** Except as established by a Council approved contract, there are established charges and rates for the use of and for the services supplied by the electric system of the City based on the amount of kilowatts consumed by the customer as shown by electric meters. Calculations of charges are made by rate tables.

Commencing with the first billing for each customer after **May 1, 2023** and on **May 1** every year thereafter, the rate tables will be reviewed and may be adjusted by the Mayor and City Council each year or at any time deemed necessary by them.

(D) **Utility Taxes.** Utility taxes are billed at a rate set by the State of Illinois; collected by the City on the billing and then are paid over to the State of Illinois monthly.

(E) **Power Cost Adjustment Charges.** These charges are billed to the City by their wholesale power providers based on consumption by the City each month. Such charges are then calculated and billed to each customer on the basis of the consumption of that individual customer.

11-1-2 **BILLING AND PAYMENT OF CHARGES.** Charges for electric services shall be made monthly. All bills for such service shall be rendered as of the **first (1st) day** of each month following the month for which service is rendered and electric meters read. All bills shall be payable by the **fifteenth (15th) day** of the month in which the bill is rendered. All bills not paid shall have a penalty of **five percent (5%)** added on the **sixteenth (16th) day** of said month. When the **fifteenth (15th) day** of any month shall be a Sunday or legal holiday, then such bills for service shall be paid on the next succeeding secular day without the penalty added.

In addition to all other charges, there shall be charged to the customer the sum of **Twenty-Five Dollars (\$25.00)** for each customer's check returned to the City for insufficient funds or other reason. Two or more such returned checks within a **six (6) month** period shall result in the requirement that all future payments to the City from that customer must be in form of either cash, money order or cashier check, unless otherwise authorized by the City Collector. All unpaid returned check charges shall be added to the customer's account and shall constitute a lien on the customer's property. (**Ord. No. 15-13; 10-06-15**)

Newton City Code

11-1-3

(A)

DISCONNECTION OF SERVICE.**Nonpayment of Bills.**

- (1) In the event charges for electric service are not paid on the **fifteenth (15th) day** of the month in which billed, a notice of disconnection shall be mailed to the customer by the City Collector on or after the **seventeenth (17th) day** of the month in which billed. Such disconnection notice shall advise the customer that service will be disconnected on or after the **fourth (4th) day** of the succeeding month, unless full payment of all delinquent charges for electricity and all penalties are paid in full to the City Collector before **8:00 A.M.** on the **fourth (4th) day** of the succeeding month.
- (2) In the event such delinquent charges are not paid in full to the City Collector by **8:00 A.M.** on the **fourth (4th) day** of the succeeding month, a delinquent fee of **Thirty-Five Dollars (\$35.00)** shall be charged to all accounts with a delinquent balance. Also, a City employee shall be sent to the premises to disconnect such delinquent user from the electric utility system without further notice.
- (3) Once disconnection has been made, no reconnection shall be made until all delinquent charges for electricity, and all penalties and delinquent fees have been paid in full to the City Collector, except, however, that if such services have been disconnected for a third time within a period of **one (1) year**, a delinquent fee of **Seventy-Five Dollars (\$75.00)** will be charged, and in addition, the delinquent fee within the succeeding year shall be **Seventy-Five Dollars (\$75.00)**.
- (4) Disconnections will be made between **8:00 A.M.** and **3:00 P.M.**, Monday through Thursday, only between **8:00 A.M.** and **12:00 Noon** on Friday, and only between **8:00 A.M.** and **12:00 Noon** when the City offices will be closed the following day. These hours provide the customer with the opportunity to make payment and have service reconnected. Reconections will be made between **8:00 A.M.** and **3:00 P.M.**, Monday through Friday.
- (5) Reconections made after **3:00 P.M.** or on holidays or weekends will have an additional charge of **One Hundred Two Dollars Fifteen Cents (\$102.15)** to cover the overtime expense.

(B)

Authorized Disconnection.

- (1) If there is no contract providing for termination of electric service, discontinuance of service at the customer's request shall be upon at least **two (2) business days'** notice to the utility. All customers terminating service shall be liable for service until the expiration of the two-day notice or until service is disconnected, whichever shall be earlier, provided immediate access is given to the utility to the equipment to disconnect the service.
- (2) The utility reserves the right to disconnect services for the following reasons without notice:
 - (a) When such action is necessary for the purpose of making repairs or in any emergency. In such case, the utility shall make every reasonable effort to restore service at the earliest possible moment. The utility shall make reasonable efforts to notify customers in advance of shutting off the supply of electric energy for the purpose of making repairs where no emergency is involved.
 - (b) If the utility discover any conditions on the customer/property owner premises dangerous to life, limb or property, the utility may disconnect service without notice until such condition shall have been remedied.

Newton City Code

- (c) Use of service for an illegal purpose.
- (C) **Avoidance of Dangerous Use Conditions.**
- (1) If a customer/property owner shall find any evidence of electrical defects in his wiring or equipment or mechanical defects or accidental damage which is likely to cause electrical trouble, he shall have such defective wiring or equipment disconnected from the utility's service as promptly as possible.
 - (2) If the customer/property owner refuses to allow the City to inspect electrical meter, metering devices, and service loop and the City of Newton Electrical Department Head or the City's Building Inspector feels it could cause harm to the owner, or the utility, service/services may be disconnected.
 - (3) The customer/property owner shall take care to maintain all structures, radio or television aerials, or other equipment clear of the utility's service drops and distribution lines, and the utility shall not be responsible for damages resulting from the customer/property owner failure to do so. Unless the customer/property owner removes any encroaching or trespassing structure on demand by the utility, the utility may remove such structure and charge the cost of removal thereof to the person responsible.
 - (4) When the City of Newton Electric Department or City Building Inspector find electrical services in need of repair/replacement and there is no danger to life, limb or property present, a written notice will be issued to the customer/property owner. Repairs or replacement must be completed within **sixty (60) days** of the notification. If repairs and/or replacement to bring the service up to the current National Electrical Code and City of Newton Electric approval are not completed within the 60-day time period, electric service will be disconnected.

(See Chapter 33 – Article III regarding trees and shrubs)

11-1-4 SERVICE DEPOSITS FOR RESIDENTIAL AND COMMERCIAL CUSTOMERS, LANDLORDS OF UNOCCUPIED RENTAL PROPERTY, AND INDUSTRIAL CUSTOMERS.

(A) **Residential.** Any person, firm or corporation, whether as owner or as tenant, who applies after **February 5, 2008** for electric service, water and/or sewer service for residential purposes, shall pay to and maintain with the City Collector a service deposit as advance security for the payment of charges for service furnished. The deposit amount shall be **Three Hundred Fifty Dollars (\$350.00)** for a current City customer with a fair payment history or a new customer with a fair credit rating. Upon transfer of a deposit, the deposit amount shall be **Five Hundred Dollars (\$500.00)** for a current City customer with a poor payment record or a poor credit rating. The deposit amount shall be **Five Hundred Dollars (\$500.00)** for a new customer with a poor credit rating. After **one (1) full year** of service history without a disconnection notice **Two Hundred Dollars (\$200.00)** of the **Three Hundred Fifty Dollars (\$350.00)** or the **Five Hundred Dollar (\$500.00)** original deposit shall be credited to the property owner's current bill as a refund. To receive the **Two Hundred Dollars (\$200.00)** credit, proof of ownership (a copy of the recorded deed) shall be provided to the City Collector. After **two (2) full years** of service history without a disconnection notice **One Hundred Fifty Dollars (\$150.00)** of the original **Five Hundred Dollar (\$500.00)** deposit shall be credited to the property owner's current bill as a refund upon the owner's request to the City Collector. Upon termination of services, the remaining property owner's deposit shall be applied to the property owner's final bill and the excess if any shall be refunded to the property owner. Upon termination of a tenant's services, the tenant's **Three Hundred Fifty Dollars (\$350.00)** or **Five Hundred Dollars (\$500.00)** deposit shall be applied to the tenant's final bill and the excess if any shall be refunded to the tenant.

Notwithstanding the foregoing, a residential customer's total deposit for electricity, water and/or sewer service shall not exceed **Five Hundred Dollars (\$500.00)**.

Newton City Code

(B) **Commercial.** Any person, firm or corporation, whether as owner, or as tenant, who applies after **November 20, 2001** for electric service, water and/or sewer service shall pay to and maintain with the City Collector a service deposit of **Three Hundred Fifty Dollars (\$350.00)** or a sum determined to be equal to the average monthly charge for such electricity, water and sewer services, whichever is greater. The average commercial consumption and billing expected to be used shall be determined by proper employees of the electric, water and sewer departments of the City. Such deposit is an advance security for the payment of charges for services furnished. After **one (1) full year** of service history without a disconnection notice any amount of the original owner's deposit exceeding the average monthly charge for electricity, water and sewer services shall be credited to the property owner's current bill as a refund. To receive credit, proof of ownership (a copy of the recorded deed) shall be provided to the City Collector. Upon termination of services, the remainder of the property owner's deposit shall be applied to the property owner's final bill and the excess if any shall be refunded to the property owner. Upon termination of a tenant's services, the tenant's original deposit shall be applied to the tenant's final bill and the excess if any shall be refunded to the tenant.

Notwithstanding the foregoing, a commercial customer's total deposit for electricity, water and/or sewer service shall not exceed **Three Hundred Fifty Dollars (\$350.00)** or a sum determined to be equal to the average monthly charge for electricity, water and sewer service, whichever is greater.

(C) **Landlords of Unoccupied Rental Property.** In lieu of a cash utility deposit of **Three Hundred Fifty Dollars (\$350.00)** or **Five Hundred Dollars (\$500.00)** an owner of an unoccupied rental property/unit, the utilities for which have been placed in owner's name, shall pay to and maintain with the City Collector a service deposit of **Fifty Dollars (\$50.00)**, **One Hundred Seventy-Five Dollars (\$175.00)** or **Three Hundred Fifty Dollars (\$350.00)**, the amount to be determined by the owner's current payment history or a current credit rating. The deposit for a good credit rating shall be **Fifty Dollars (\$50.00)**, a fair credit rating shall be **One Hundred Seventy-Five Dollars (\$175.00)** and a poor credit rating shall be **Three Hundred Fifty Dollars (\$350.00)**. Upon rental/occupancy of the property/unit a cash deposit shall be required in accordance with present Ordinance, irrespective of whether the utilities remain in the owner's name or are placed in the renter's name.

(D) **Industrial.** Any person, firm or corporation, whether as owner, or as tenant, who applies after **March 18, 2008** for electric service, water and/or sewer service shall pay to and maintain with the City Collector a service deposit of **Three Hundred Fifty Dollars (\$350.00)**. Such deposit is an advance security for the payment of charges for services furnished. Upon termination of service, the original deposit shall be applied to the final bill and the excess if any shall be refunded to the customer. To be eligible for the **Three Hundred Fifty Dollar (\$350.00)** Industrial Rate deposit, the customer must create **ten (10)** or more new jobs within the **first (1st) year** of their doing business in the City and retain those jobs or a minimum of **five (5) years**. The Industrial Rate deposit amount of **Three Hundred Fifty Dollars (\$350.00)** shall terminate automatically if the new employer (1) fails to create **ten (10)** or more full-time jobs in the City within the **first (1st) year** or (2) fails to retain those **ten (10)** or more jobs for a minimum of **five (5) years**, at which time the Commercial Deposit policy shall be enforced.

(Ord. 08-8; 03-18-08)

11-1-5 TAMPERING. It shall be unlawful for any person not authorized by the City to tamper with, alter, or injure any transmission conduits, impair, interrupt any power or appurtenances thereto utilized to provide electrical service to customers of the City of Newton's electrical distribution system, or to tamper with, alter, bypassed so as to cause a lack of measurement or inaccurate measurement, or to obtain utility service without the permission of the City on premises controlled by the customer or by the person using or receiving the direct benefit of utility service at that location, or injure any meter utilized to record electricity consumed by a customer. The removal of a tag or seal on an electric current meter or an outdoor breaker box or the use of an electric current meter other than the meter assigned by the City to that location is prohibited.

Any person found to be in violation of this provision shall be subject to the penalties provided for in this Code (**See Section 1-1-20**) and shall be reported to the Jasper County State's Attorney for prosecution for tampering under the Illinois Criminal Code. Additionally, any service that has been

Newton City Code

tampered with or with the intent to defraud the utility, shall be disconnected and removed without prior notice. Service shall not be restored or activated until all damages or estimated amount, if any, of the loss due to such tampering or fraud to the City's equipment, all consumption charges, including those for estimated lost consumption, the required service deposit and the required reconnection charge have been paid in full.

The utility may require wiring changes by any customer whose service has been disconnected for fraudulent tampering so that there can be no recurrence of the violation. Such required changes include the removal of the utility's metering equipment to a new location outside the customer's premises.

11-1-6 EXCEPTIONS TO DISCONNECTION OF SERVICE.

(A) No electric service furnished to a residential customer by the City shall be terminated for nonpayment of bills on:

- (1) Any day when the national weather service forecast for the following **twenty-four (24) hours** covering the area in which the residence is located includes a forecast that the temperature will be **twenty (20) degrees Fahrenheit** or below; or
- (2) Any day preceding a holiday or a weekend when such a forecast indicates that the temperature will be **twenty (20) degrees Fahrenheit** or below during the holiday or weekend.

(B) Anyone with a serious illness necessitating the need for continuation of electric service who is living full time at a residence scheduled for disconnection of service may contact a duly licensed physician. If the City Clerk receives, prior to disconnection of service, a written confirmation of the illness from a duly licensed physician, the electric service shall not be disconnected for a period of **thirty (30) days** from the day the written confirmation is received by the City Clerk if the customer complies with both of the following conditions, to-wit:

- (1) The duly licensed physician's statement must include the name, address and telephone number of the ill person; verification that the ill person is a full-time resident of the premises; the nature and duration of the illness verifying that termination of the electric service in question will create a life-threatening situation; and the business name and telephone number of the certifying physician.
- (2) The customer must make full payment of all delinquent electric service charges and all penalties within **thirty (30) days** after the City Clerk's receipt of the said physician's written confirmation otherwise, the electric service shall be disconnected on or after the **thirty-first (31st) day** after the Clerk's receipt of the said written physician's confirmation.
- (3) The City reserves the right to verify any and all information concerning a customer's illness.

(C) Any person receiving a disconnection notice who believes there has been an error in billing, malfunction of metering equipment or other just cause, may request a hearing before the City Council. A request for hearing by the customer must be submitted in writing to the City Clerk before disconnection has occurred. The hearing will take place within **fifteen (15) days** of the receipt of the customer's request for hearing. A decision will be rendered following the hearing. A decision will be rendered following the hearing. Until the hearing has been held and decision rendered, the customer's service will not be disconnected. Should the City Council's decision after the hearing be to disconnect the electric service, the customer will be so notified by written notice not less than **seven (7) days** prior to disconnection of service.

(Unless Otherwise Noted; Ord. No. 01-24; 11-20-01)

11-1-7 LIABILITY OF CITY.

(A) The electric utility shall not be liable to the customer/property owner for interruption or inadequacy of service, loss or damage to property or injury, including death, to any person

Newton City Code

caused by an act of God; public enemy; vandalism; strikes and other labor troubles or their equivalent; legal process; state, municipal or other governmental regulation; windstorm; flood; fire or explosion or other matter or thing beyond the utility's control, whether such shall affect or occur in connection with the operations or property of the customer/property owner, utility or any other person.

(B) The utility shall not be responsible in damages for any failure to supply electricity or for interruption or reversal of the supply, if such failure, interruption, or reversal is without willful default or negligence on its part, nor for interruptions, by under-frequency delays or otherwise, to preserve the integrity of utility's system or interconnected systems.

(C) The utility shall not be liable to the customer/property owner for damage or injury, including death, to person or property caused by electric energy and occurring at any place beyond the point of which such electric energy first passes to the wires or other facilities or equipment owned or controlled by the customer/property owner, and the customer/property owner shall protect and save harmless the utility from all such damage or injury, including death, occurring at any place beyond the point except where injury or damage shall be shown to have been occasioned solely by the negligence of the utility.

(D) The customer/property owner shall be held responsible for all electric energy used on the premises until written notice of termination of service is received by the utility and the utility shall have taken the final meter readings.

(E) Inspection by agents of the utility or the utility's failure to reject an application for service, or the commencement or rendition of service by the utility, shall not constitute an admission or agreement, either expressed or implied, as to the adequacy, safety, or other characteristics of any electrical installation on the customer/property owner premises not owned or maintained by the utility.

(F) No claim for damages shall be made against the City by reason of the breakage of any transformer, reducer, meter or wire carrying current; nor shall the City be liable in damages to any consumer deprived of electrical current by reason of any breakage or any machinery or stoppage for improvement or repair; nor shall the City be liable for any loss, injury or damage resulting from the interruption, restoration or reduction of electrical service from any cause.

(G) The utility desires at all times to furnish any and every customer/property owner sufficient capacity to meet any reasonably permanent service requirement. However, service connections, meters, transformers, and other equipment supplied by the utility for the customer/property owner service have definitely limited capacity. Accordingly, any customer/property owner contemplating installation of additional equipment or material changes in equipment or wiring should give reasonable notice to the utility before such changes are undertaken, and the utility shall not be responsible for losses or damages resulting from the addition or changes of equipment.

(H) The customer/property owner shall exercise due care to avoid damage to the utility's meter as well as unsafe or unsanitary conditions adjacent to the utility's meter and the other service facilities of the utility located on the customer/property owner premises. The utility shall have the right to reject any application for service or to terminate service to any customer/property owner whose premises, in the judgment of the utility, are dangerous to persons or are otherwise unsafe in the vicinity of the utility's meter and other facilities. If meters or other facilities belonging to the utility are damaged or destroyed, due to negligence or misuse by the customer/property owner or by any member of his family or by any officer, agent, or employee of the customer/property owner or by subtenants, the cost of necessary repairs or replacements shall be paid by the customer/property owner.

(I) If the customer/property owner operation or the manner in which the customer/property owner uses the utility's service causes damage to the utility's facilities on the customer/property owner premises, the customer/property owner shall pay the amount of such damage to the utility on demand.

11-1-8 RIGHT TO ENTER PROPERTY. By applying for or taking electric service from the utility, a customer/property owner grants to the utility the right to enter upon the premises to be served and to install or remove, repair, or maintain thereon its lines, meters, and other City-owned facilities for the purpose of serving such customer/property owner. The customer/property owner shall afford the utility's representatives free access to his premises at all reasonable hours for the purpose of reading the meter or inspecting the metering equipment and all other equipment relating to the utility's

Newton City Code

service or for making the necessary repairs or tests to its equipment or for removing its meter and equipment. The customer/property owner shall afford the utility's representative access to mark underground facilities located on customer/property owner property when a JULIE locate is called in to locate as per **220 ILCS 50/ Illinois Underground Utility Facilities Damage Prevention Act.**

11-1-9 BACKFEEDING TO CITY ELECTRICAL DISTRIBUTION SYSTEM.

Backfeeding means to energize a section of utility distribution system from customer side of the meter with a generation of power from solar, wind, energy storage systems, generator, etc. Backfeeding is a dangerous process. It can pose a serious threat not only to you, but also to your neighbors and utility workers. No backfeeding is allowed without proper electrical devices as per the current NFPA 70 National Electrical Code and approval of the City electric department. All services with any capabilities of backfeeding will be tested to insure when City electrical distribution is offline there is no backfeeding from service. This must be done before final approval of services. Any services that are found backing feed from any solar, wind, energy storage systems, generator, etc., not approved will be disconnected until removal of interconnection or proper electrical devices are installed as per the NEC.

[Unless Otherwise Noted, This Article Ord. No. 2024-08; 05-21-24]

Newton City Code**ARTICLE II – METER LOCATIONS/METERING DEVICES**

11-2-1 REGULATIONS FOR ELECTRIC METERS. The regulations applicable to electric meters are as follows:

- (A) All services must have an outside disconnect no further than **four (4) feet** from the meter base.
- (B) Meter base and service disconnect must be mounted **three (3) feet** or more from gas meters, doors, windows, and air conditioning units of the building as shown in Figure 2.
- (C) All service entrance wire must be in Schedule 40 conduit metal or PVC depending on type of service. No coupling of service mast above last point of securement.
- (D) A minimum of **three (3) feet** of conductor must extend out of the weather head for connection to the service drop conductors. The neutral conductor **must** be identified.
- (E) Services with risers must extend **twenty-four (24) inches** over roof line and any over **thirty-six (36) inches** must have support/guy wire.
- (F) Only overhead electrical service wire or power service conductors be permitted to be attached to service mast.
- (G) Three conduit straps are needed every **ten (10) feet** on service entrance conduit. Three conduit straps are needed every **five (5) feet** on ground wire conduit.
- (H) Customer/Property owner supplied ground rod shall be **five-eighths (5/8) inch** by **eight (8) feet** copper clad and clamp shall be installed.
- (I) Service that extends over **sixty (60) feet** from pole to pole or **eighty (80) feet** from pole to service mast must have a guy or a support wire.
- (J) No overhead mast service will be allowed on a mobile, manufactured, or modular home.
- (K) All connections must use a corrosion inhibitor.
- (L) No used poles will be allowed for meter poles or lift poles.
- (M) No self-contained meter will be used for volts 480 and over. Current Transformers (CT) and Voltage Transformers (VT) will be installed at the cost of the customer.
- (N) **Manual Bypass Meter Sockets.** The customer/property owner shall install, at its sole cost, a City of Newton approved manual bypass meter socket with the ability to break load at full rating for each of the following installations:
 - (1) All commercial installations (lever bypass); and
 - (2) All residential installations rated over 200 amperes (lever bypass); and
 - (3) All multi-unit residential installations.

11-2-2 LOCATION OF METERING EQUIPMENT.

- (A) Metering equipment will consist of instrument transformers, City-approved instrument transformer cabinet and appropriate conduit and fittings.
- (B) Unless otherwise approved by the City, all metering equipment shall be located outside of the customer building at a location adjacent to where the main service entrance conductors attach to the customer's building.
- (C) The customer shall provide a suitable place on his or her building for the installation of the metering equipment.
- (D) The metering equipment shall be so located that adequate space and unobstructed access (i.e. cannot be located within a fenced in area) are provided for the purposes of reading, testing, inspecting, and exchanging of such equipment by City personnel. The customer shall consult the City regarding the proper location of the equipment.
- (E) The metering equipment location shall be free from moisture, but when a damp location is unavoidable, the customer shall furnish and install, at his or her own expense, a moisture-proof cabinet to contain the metering equipment.
- (F) Metering equipment shall not be placed underneath water pipes or other piping systems.

Newton City Code

(G) Metering equipment shall not be placed closer than **ten (10) feet** from a gas service entrance, gas regulator, or gas appliance of any type.

(H) If there is a possibility that the metering equipment may be exposed to excessive dust, metal filings, or similar substances, the customer shall furnish and install, at his or her own expense, a suitable dust-proof enclosure to protect the equipment.

11-2-3 LOCATION OF METERS.

(A) All existing services must meet or exceed 2002 National Electric Code Specifications for existing services. All new or replacement services must meet the current NFPA 70 National Electric Code.

(B) The City Electric Department reserves the right to accept or reject any service.

(C) All electric meters shall be located on the outside of the customer's buildings, except such commercial customers where it may be desirable for the utility to designate other locations. The enclosing of any outside meter will not be permitted.

(D) Electric meter under carports, inside buildings, inside screened-in porches, under cover porches, over decks, fenced-in back yards and any inaccessible meters will not be connected.

(E) Electric meter shall not be placed where access is only available using stairs.

(F) Electric meter shall not be placed where it is not possible to read and service meter without the use of stepladders or other aids.

(G) Electric meter shall not be placed on City-owned utility poles. In the event the City replaces a utility pole on which a customer/property owner meter socket is located, the affected customer/property owner shall be responsible for the relocation of the meter socket to a location permitted by this Article.

(H) For buildings with two or more meter sockets, all the meters shall be grouped together ("ganged") in a common area accessible to City personnel.

(I) The utility reserves the right to determine and designate the locations of all electric meters. Whenever in the opinion of the utility any electric meter is not readily accessible for reading or any other necessary maintenance, the meter shall be relocated by the customer. Any expense incident to changing the location of meters to conform to the requirements of the utility shall be borne by the property owner, or the person in whose name service is being supplied.

(J) An approved location for the point of delivery to a customer/property owner premises will normally be between the midpoints of the building from the corner nearest the City's distribution system. A and C are the midpoints of the building. The service may be located anywhere between A and B or B and C observing clearance requirements from windows, chimneys, driveways, trees, etc.

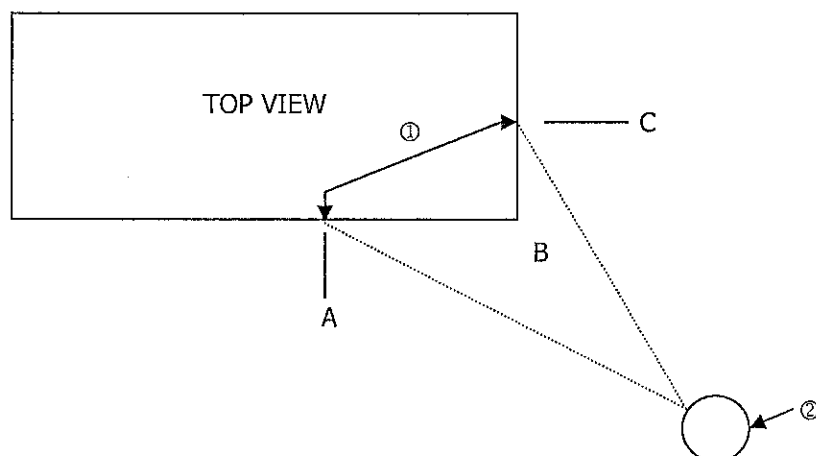

(K) Service loop and service wire must maintain clearances as shown in Figure 1 and Figure 2.

(L) The center of the meter baser must be no lower than **sixty (60) inches** and no higher than **sixty-six (66) inches** from final grade.

Newton City Code

Meter Locations/Metering Devices

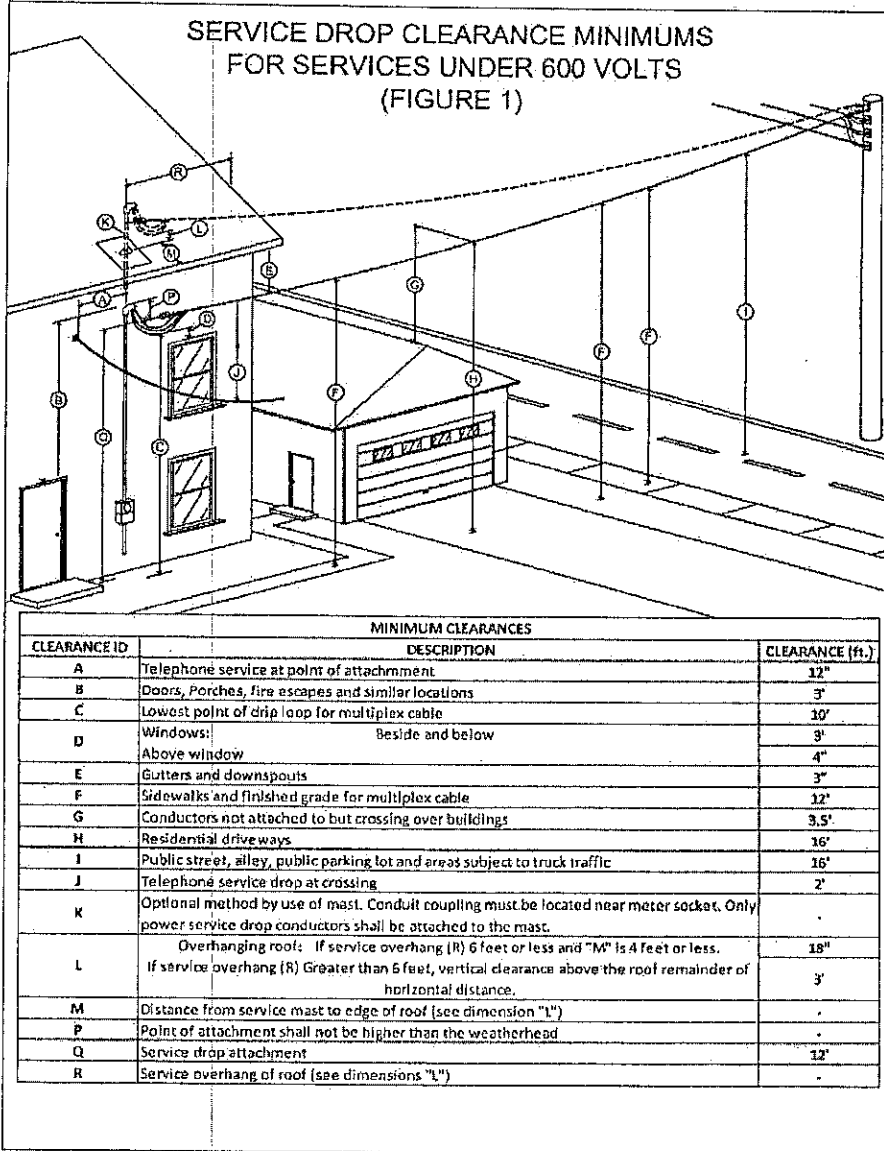

Newton City Code

Meter Locations/Metering Devices

Figure 2

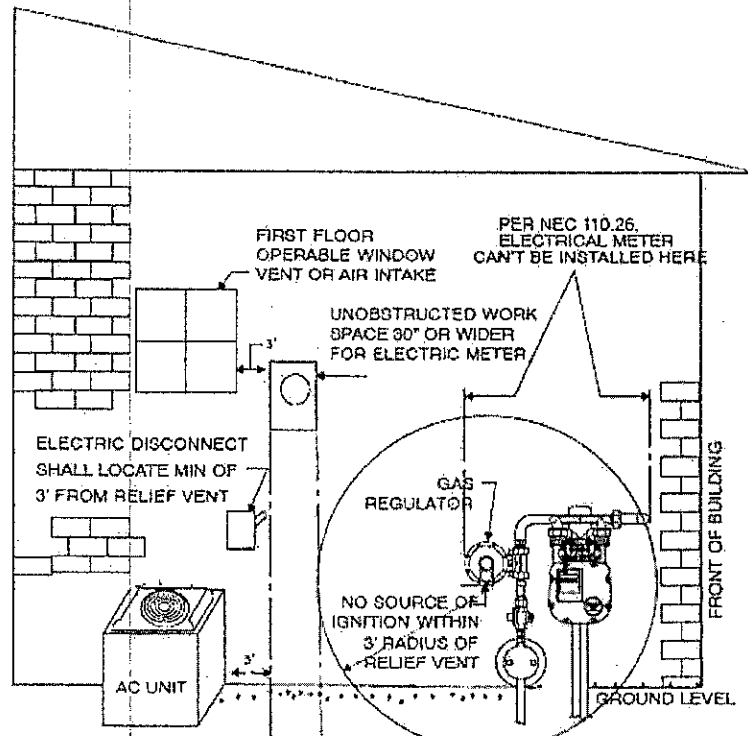

NOTE: METER EQUIPMENT'S LOCATION MUST SATISFY NEC 110.26, BOTH 3' VENT CLEARANCE TO GAS METER, AND 30" WORKING SPACE

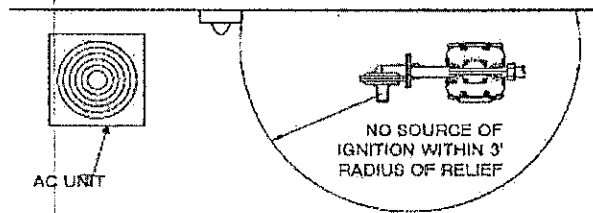

ARTICLE III – ECONOMIC INCENTIVES

11-3-1 INCENTIVE ESTABLISHED. The Mayor or other authorized office of the City is hereby authorized to negotiate with and offer to any individual, association, corporation or other legal entity proposing to come to the City and create **ten (10)** or more new jobs a **five (5) year** contract which contains the following terms:

(A) An employer creating **ten (10)** or more full-time jobs within the **first (1st) year** of their doing business in the City and retaining those jobs for a minimum of **five (5) years** will be eligible for electric rate discounts as follows:

(1) Years 1-5 – Industrial Rate which shall be a rate equal to the City Rate which changes when the City’s supplier’s rate changes.

Rates and Charges for Electric System, Utility Taxes and Power Cost Adjustment Charges apply as defined in the Newton City Code.

(2) Year 6 – Graduated Industrial Rate as defined in the following billing rate table:

- For the first 115 KWH used per month at \$0.192064
- For the next 135 KWH used per month at \$0.159684
- For the next 250 KWH used per month at \$0.144052
- For the next 500 KWH used per month at \$0.135118
- For all over 1000 KWH used per month at \$0.117700

The minimum charge for electricity used for commercial purposes shall be **Twenty-Two Dollars Nine Cents (\$22.09)** per month for the first **one hundred fifteen (115) KWH**.

Rates and Charges for Electric System, Utility Taxes and Power Cost Adjustment Charges apply as defined in the Newton City Code.

(3) Year 7 – Commercial Rate as defined in the City Code.

(B) The foregoing rates would not change during the term of the contract unless the City’s cost from its wholesale power provider changes then any increases would be passed on to the customer.

(C) The foregoing discounted rates shall terminate automatically if the new employer (1) fails to create **ten (10)** or more full-time jobs in the City within the **first (1st) year**; (2) fails to retain those **ten (10)** or more jobs for a minimum of **five (5) years** or (3) fails to meet any other of its obligations to the City. In the event of said termination, the new employer must agree to reimburse the City the difference between the discounted electric rate and the normal electric rate that would have been charged to the new employer, said difference to be paid to the City within **sixty (60) days** from the date of said termination.

(Ord. No. 2024-08; 05-21-24)

ARTICLE IV - NET METERING POLICY

11-4-1 NET METERING POLICY. The City hereby adopts the new Net Metering Policy set forth in Exhibit A attached hereto, the new Terms and Conditions for Interconnection set forth in Exhibit B attached hereto, the new sample One-Line Interconnection Diagram set forth in Exhibit C attached hereto, the new Standard Distributed Generation Interconnection Request Application Form set forth in Exhibit D attached hereto, the new Standard Distributed Generation Interconnection Request Application Form set forth in Exhibit E attached hereto, and the new Certificate of Completion set forth in Exhibit F attached hereto, all of which are incorporated herein by this reference.

The effective date of the new Net Metering Policy and affiliated exhibits above described shall be May 3, 2022. Any electric generating facility operating within the City before the effective date of this Article, shall be grandfathered in and shall be governed by the old Net Metering Policy until the facility ceases to operate or there is a transfer of ownership, at which time the generating facility shall be governed by this new Article.

(Ord. No. 22-09; 05-03-22)

Newton City Code

EXHIBIT A

CITY OF NEWTON NET METERING POLICY

EFFECTIVE DATE: NOVEMBER 19, 2019

Section 1: The City of Newton ("City") shall make available, upon request, net metering service to any customer taking service from the City and who meets the requirements set forth in this policy. For purposes of this policy "net metering" means service to an electric customer under which electric energy generated by that electric customer from an eligible on-site generating facility owned by that customer and, under some circumstances, delivered to the local distribution facilities, may be used to offset electric energy provided by the electric utility to the electric customer as provided for in this policy. The term "net metering" is not used as a limiting term, but rather is used in its general sense to include the full range of methods for valuing customer self-generation and implementing fair credits for excess energy delivered to the municipal distribution system by the customer. For multi-unit residential and commercial buildings, if all units are on the same account it qualifies as a single customer for purposes of this policy. If individual units are separately metered and individual tenants have individual accounts, then the term "customer" only refers to the building owner and any usage by the owner. The City cannot be responsible to allocate renewable generation facilities to individual accounts in a multi-unit residential or commercial building. Before the project starts construction, customer must complete the attached application form and receive approval from the Newton Electric Department. Before the project in service date, the contractor must complete and deliver the attached Certification of Completion to the Newton City Hall.

Section 2: For purposes of this policy an eligible on-site generating facility shall be defined as a renewable generating facility, such as a photovoltaic facility and small wind turbines, and may include technology to store renewable energy at the customer's premises. Other forms of renewable generation shall be considered on a case-by-case basis. In all cases, facilities interconnected must be deemed by the City to be renewable to qualify for this policy.

Section 3: The electric generating facility must also abide by the City Interconnection Standards currently in place at the time of installation to be an eligible one-site generating facility.

Section 4: Subject to the limitations set forth herein, the City shall make net metering service available upon request to any City residential or small commercial electric customer with an eligible on-site generating facility owned by the customer. The determination whether a customer is a residential or small commercial customer is based on the rate classification under which the customer takes electric service. Small commercial customers are further defined as those with single phase service. The eligible on-site generating facility shall be located on the customer's premises and on the customer's side of the billing meter and be sized to primarily produce only enough electricity to offset the customer's own electrical requirements. Proper sizing of eligible on-site generating facilities shall be determined as set forth in Section 13 below.

Section 5: Any request for net metering service by a customer that is not a residential or small commercial customer shall be considered on a case-by-case basis. The decision with respect to such facilities shall be made by the City Electric Department based on potential impacts to the distribution system or portions thereof and to the property of other customers of the City. Customers that do not qualify for net metering service under this Policy shall be permitted to interconnect and self-generate as required by and in accordance with the Federal Energy Regulatory Commission's rules under the Public Utility Regulatory Policies Act (PURPA) on a case-by-case basis.

Section 6: Notwithstanding the provisions in Section 4, the City reserves the authority to withhold, deny or delay approval of the interconnection of proposed on-site generating facilities and of net metering service hereunder if the operation of the facility would be unsafe or pose a risk of adverse impacts to the distribution system or portions thereof or to the property of other customers of the City. The City shall withhold approval for only so long as is reasonably necessary to remedy the risk of adverse impact. The City shall only deny

Newton City Code

approval if the adverse impact cannot reasonably be remedied or if the customer refuses to meet all applicable State and local safety and electrical code requirements or refuses to provide for payment of the costs of the improvements to the facility or the system that are required to accommodate the otherwise eligible on-site generating facility. The City shall not be required to make unscheduled improvements to its distribution system or portions thereof to remedy the situation causing the delayed or withheld approval unless the customer agrees to pay for the reasonable costs thereof. Likewise, the City may require a customer with an approved on-site generating facility that has been installed and begun to operate to suspend operations of the facility if it becomes unsafe or causes adverse impacts to the distribution system or portions thereof or to the property of other customers of the City, and such suspension shall be in place only so long as is reasonably necessary to remedy the adverse impact. The City may require the customer to disconnect the on-site generating facility from the distribution system in serious situations.

Section 7: [This Section left blank intentionally.]

Section 8:

- A. Energy generated by the customer-owned generator during the billing period may supply all or a portion of the energy required by the customer's load. The customer shall be credited for excess energy delivered by the customer to the City at the meter from the approved on-site generating facility.
- B. For eligible on-site generating facilities that were approved and in service on or prior to the effective date of the 2022 revisions to this Policy, the following credit method shall be used to determine excess energy credit until April 30, 2032: For energy delivered by the utility to the customer at the meter, as reflected in the meter reading, shall be billed at the appropriate utility full retail energy rate. For any excess energy generated by the customer from an approved on-site generating facility and delivered by the customer to the utility at the meter, as reflected in the meter reading, a credit shall be created and applied to the customer's bill based on the avoided cost of energy. Avoided cost shall be determined as set forth in Section 12 below. The City shall install an appropriate meter to measure both the energy delivered by the utility to the customer at the meter and the energy delivered by the customer to the utility at the meter from the approved on-site generating facility. For all other eligible on-site generating facilities, and after April 30, 2032 the above-referenced customers, the following credit method shall be used to determine excess energy credit: For energy delivered by the utility to the customer at the meter, as reflected in the meter reading, shall be billed at the appropriate utility full retail energy rate. For any excess energy generated by the customer from an approved on-site generating facility and delivered by the customer to the utility at the meter, as reflected in the meter reading, a credit shall be created and applied to the customer's bill based upon the avoided cost of energy. Avoided cost shall be determined as set forth in Section 12 below. The City shall install an appropriate meter to measure both the energy delivered by the utility to the customer at the meter and the energy delivered by the customer to the utility at the meter from the approved on-site generating facility.
- C. Credits from electric energy delivered to the municipal distribution system by the customer shall be used to offset usage based electric energy (kWh) charges only. No such credits shall be applied to, and the customer shall remain responsible for, (i) taxes, fees, and other charges that would otherwise be applicable to the net amount of electric energy (kWh) purchased by the customer from the City or consumed by the customer, and (ii) other charges to the customer under any other rules, regulations or rates that are not based on per kilowatt-hour (kWh) charges, including but not limited to, basic service charges, customer service charges, facilities charges, demand charges, kVAR charges, transformation charges, taxes and assessments billed on other than kWh basis, rental fees, and late fees.
- D. The City shall carry over any unused credits earned and apply those credits to subsequent billing periods to offset usage based electric energy (kWh) charges only for electric energy supplied to the customer by the City until all credits are used or until the end of the annual period. The annual period shall end each year on the last day of February; provided however for new net metering customers with generating facilities installed during an annual period, the annual period shall end of February 28 of the following year. At the end of the annual period or in the event that the customer terminates service at the service location with the City prior to the end of annual period, any remaining credits in the customer's account shall expire and no credit or payment shall be due to the customer for such expired credits. In the event of termination of an account qualifying for net metering under this policy, any outstanding credits are surrendered. No credit or payment shall be due to the customer for such surrendered credits. Under no circumstance will credits for excess energy transfer to a new customer at the service location after the customer's service with the City terminates.

Newton City Code

Section 9: Any costs the City incurs associated with the interconnection of generating facilities by a customer, including but not limited to changes in metering (to include installation of a bi-directional meter), or other physical facilities, whether on the customer's premises or a reasonably necessary upgrade to the municipal distribution system or a portion thereof that is not on the customer's premises, shall be borne by the customer seeking to install or for whom the generating facility was installed; provided however that such costs shall be capped at \$1,500 to each qualifying customer interconnecting facilities of 10 kW or less. For those facilities greater than 10 kW that are deemed to qualify under this policy, all costs associated with the interconnection of the generating facility shall be borne by the customer seeking to install or for whom the generating facility was installed. Costs assessed under this Section shall be demonstrable and cost based. Such costs shall not include or be based on reduced sales by or lost revenues to the City associated with net metering service.

Section 10: [This Section left blank intentionally.]

Section 11: The City shall develop such documents as needed to implement this policy and any customer applying for or taking service hereunder shall execute all appropriate documents. See Interconnection Agreement Exhibit B – F.

Section 12: The utility shall install a bi-directional meter to measure both the energy used by the customer from the utility and the energy provided by the customer to the utility. Energy generated by the customer-owned generator will offset the energy required by the customer's load during the billing period. Energy used by the customer from the utility, as reflected in the meter reading, shall be billed at the appropriate utility full retail rate. For any energy generated by the customer and provided to the utility for a given billing period, as reflected in the meter reading, a credit shall be applied to the customer's bill based upon the utility's cost. Avoided cost shall be defined as the average cost in cents/kWh billed to the utility by its power supplier for the previous month.

Section 13: The maximum size in kilowatts_{AC} of the eligible on-site generating facility for an individual customer service location in the rate categories identified in Section 4 shall be determined as follows:

The installation of a renewable generating facility under this Policy is intended to supply all or a portion of the customer's own usage of electricity. Therefore, in order to be approved, a renewable generating facility must be properly sized so as to meet a residential customer's peak demand of electricity or 10 kW, whichever is greater, or the small commercial customer's peak demand of electricity or 25kW, whichever is greater. It is also important to the customer that the generating facilities are properly sized because the credits under this Policy for excess energy delivered to the distribution system expire if not used within the time period established in this Policy. As part of the interconnection application, customer's energy usage will be analyzed using 36-months of historical energy usage (if available) in order to calculate the customer's expected peak demand. If a customer provides documentation specifying why the usage has increased over that time, such as home renovation/addition or installation of electric heating or an electric vehicle charging station on the premises, then the previous 12-month period shall be used to determine the average for the expected peak demand. If the applicable months of data are not available for an individual customer, the average usage amounts by other similar customers of the City, as determined by the City Electric Department, shall be used to set the expected peak demand. If facilities are allowed for customers in other rate classes, the rightsizing shall be determined on a case-by-case basis.

In addition to the foregoing historic usage, the City shall consider potential adverse impacts to the distribution system and to other customers of the City that will be caused by or expected to be caused by the installation of the new renewable generating facility at the particular customer service location as part of the interconnection application review. The maximum size of the eligible on-site generating facility for an individual customer service location shall be reduced below the expected peak demand of the customer to mitigate the potential adverse impacts to the distribution system or portions thereof and to the other customers of the City unless the customer pays for any necessary upgrade to the system or portion thereof to avoid the potential adverse impact.

Section 14: Any customer with an approved on-site generating facility that was approved and in service on or prior to the effective date of the 2022 revisions to the Policy may elect to be treated as if it were placed in service after the effective date of the 2022 revisions to this Policy for purposes of the legacy netting and

Newton City Code

crediting provisions in Sections 8 and 12. There is a limited one-time option to make such election. The customer shall make any such election within 60 days of the effective date of the 2022 revisions to this Policy.

Section 15: The City reserve the right to interpret, amend or rescind this policy. Nothing herein is intended to nor shall it create a right for a customer to rely on any particular netting or crediting methodology contained in the policy from time to time, and all rates for excess credits are subject to change in accordance with the laws of the State of Illinois governing municipalities.

Section 16: Citizen and customer concerns generally with this Net Metering Policy may be raised in the public comment portion of any open meeting of the governing body of the City at any time and will be considered by the governing body in accordance with its normal processes. Individual customer complaints, disputes or concerns shall be raised in the first instance with the City Electric Department Head. If the matter cannot be resolved at the utility staff level, this issue shall be reduced to writing and forwarded to the City Electric Department chairman who shall schedule a meeting in person or by telephone or other communications media (i.e., Zoom call) with the customer. The customer may invite its contractor or other consultant to participate in the meeting. If the matter cannot be resolved at this stage, the process will escalate to the Mayor and City Council. If this process fails to resolve the matter, the customer may appeal it to the circuit court and exercise whatever rights and remedies the customer may have in law or equity. This policy shall be posted on the City's website along with appropriate contact information.

Newton City Code**EXHIBIT "B"****Customer-Owned Generating
FACILITIES INTERCONNECTION AGREEMENT**

This Agreement ("**Agreement**") is entered into by and between the City of Newton, ("**Utility**") and _____ ("**Customer**"). Customer and Utility are referenced in this Agreement collectively as "**Parties**" and individually as "**Party**".

Recitals

WHEREAS, Utility is a municipality-owned electric utility engaged in the retail sale of electricity in the State of Illinois.

WHEREAS, interconnection Customer is proposing to install, own, and operate an electric generating facility, or is proposing a generating capacity addition to an existing generating facility that qualifies under the Utility's Customer Self-Generation Interconnection Policy (adopted May 3, 2022) consistent with the interconnection agreement completed by interconnection Customer on _____.

Agreement

NOW, THEREFORE, in consideration of the covenants and promises herein, the parties mutually agree as follows:

Article I – Scope and Limitation of Agreement

- 1.1 **Scope of Agreement.** This Agreement governs the terms and conditions under which the Customer's generating facility will interconnect with, and operate in parallel with, the distribution system. Terms used in this Agreement and not otherwise defined shall have the respective meaning given to them in the Utility's Customer Self-Generation Interconnection Policy.
- 1.2 **Eligibility.** Interconnection to the electric system shall be granted only to new or existing Customers in good standing under the Utility's terms, conditions, rules, regulations and provisions for electric service. The Interconnection Agreement shall be between the Customer who owns the generating facility and the Utility.
- 1.3 **Request.** A Customer desiring to interconnect a qualifying generating facility must complete and return to the Utility an Interconnection Request Application Form with payment of the applicable processing fee. The processing fee for systems sized 25 kW_{AC} and under is \$100. The processing fee for systems sized greater than 25 kW_{AC} is \$200. The Utility may require additional details or clarifications as needed to properly evaluate the application.
- 1.4 **System Effects.** The Utility will analyze the overall impact of the proposed generating facility on the distribution system. Such analyses will be based on Good Utility Practice to determine thermal effects, voltage fluctuations, power quality, system stability, and other parameters.
- 1.5 **System Upgrades.** As a result of the analysis described in Section 1.4, the Utility will provide the Customer with a cost estimate and projected timeframe for any distribution system upgrades that may be necessary to accommodate the generating facility.
- 1.6 **Metering.** The interconnection Customer shall be responsible for the cost to purchase and install appropriate metering. Exhibit C illustrates the sample of interconnection and metering requirement, ownership and responsibilities of the Parties.
- 1.7 **Codes and Permits.**
 - A. The interconnection Customer shall be responsible for procuring all building, operating, and environmental permits that are required by any governmental authority having jurisdiction for the type of generating facility and for the necessary ancillary structures to be installed, if any.
 - B. The equipment shall meet the standards listed in Section 2.7.
 - C. The construction and facilities shall meet all applicable building and electrical codes.

Newton City Code**Article II – Technical Requirements**

- 2.1 **Character of Service.** The electrical service shall be 60 cycles per second (60 Hertz) alternating current (AC) at supply voltages and number of phases that apply under the Utility's terms, conditions, rules, regulations and provisions for electric service, including metering requirements.
- 2.2 **Code Requirements.** Once the generating facility has been authorized to commence parallel operation, the interconnection Customer shall abide by all operating procedures established by the National Electrical Code (NEC), National Electrical Safety Code (NESC), Institute of Electrical and Electronics Engineers (IEEE), Underwriters Laboratories (UL), and Occupational Safety and Health Administration. Specific codes are listed in Section 2.7 below as "National Certification Codes and Standards." In addition, Manufacturer's Ownership, Operating and Maintenance Manuals shall be reviewed and accepted by both parties prior to beginning operation.
- 2.3 **Generating Facility Control and Operation.** The control system of the generating facility shall comply with the IEEE specifications standards for parallel operation with the Utility and in particular as follows:
- A. Power output control system shall automatically disconnect from distribution system upon loss of Utility voltage and not reconnect until Utility voltage has been restored and stabilized by the Utility.
 - B. Power output control system shall ride through voltage fluctuations but shall automatically disconnect from distribution system if Utility or Customer-owned generation voltage fluctuates beyond plus or minus 10% (ten percent). The interconnection Customer shall provide adequate protection to prevent damage to the distribution system from inadvertent over/under voltage conditions originating in Customer's generating facility and to protect the Customer's generating facility from inadvertent over/under voltage conditions originating from the distribution system.
 - C. Power output control system shall ride through frequency fluctuations but shall automatically disconnect from Utility if frequency fluctuates beyond plus or minus 2 cycles per second from 60 cycles per second (Hertz).
 - D. Inverter output distortion shall meet IEEE requirements.
 - E. the generating facility shall meet the applicable IEEE standards concerning impacts to the distribution system with regard to harmonic distortion, voltage flicker, power factor, direct current injection and electromagnetic interference.
 - F. The voltage produced by the Customer's generating facility must be balanced if it is a three-phase installation. The interconnection Customer is responsible for protecting the generating facility from an inadvertent phase imbalance in the Utility's service voltage.
- 2.4 **Fault Current Contribution.** The generating facility shall be equipped with protective equipment designed to automatically disconnect during fault current conditions and remain disconnected until the voltage and frequency have stabilized.
- 2.5 **Reclosing Coordination.** The generating facility shall be coordinated with the distribution system reclosing devices by disconnecting from the system during the initial de-energized operation and shall remain disconnected until the voltage and frequency have stabilized.
- 2.6 **Disconnect Device.** A safety manual disconnect switch of the visible load break type shall be installed by the customer. The disconnect switch shall be visible to and readily accessible by Utility personnel. The switch shall be capable of being locked in the open position and shall prevent the generator from supplying power to the distribution system.
- 2.7 **Standards for Interconnection, Safety, and Operating Reliability.** The interconnection of a generating facility and associated interconnection equipment to the Utility's distribution system shall meet the applicable provisions of the following publications:
- A. ANSI/IEEE1547-2018 Standard for Interconnecting Distributed Resources with Electric Power Systems (including use of IEE 1547.1-2020 testing protocols to establish conformity) as they may be amended from time to time. The following standards shall be used as guidance in applying IEEE 1547;
 - B. IEEE Std 519-2014, IEEE Recommended Practices and Requirements for Harmonic Control in Electrical Power Systems;

Newton City Code

- C. IEEE 1453, IEEE Recommended Practice for the Analysis of Fluctuating Installation on Power Systems;
- D. UL1741 requirement for inverter-based generation;
- E. NESC Electric Safety Code;
- F. ANSI/NFPA 70, National Electrical Code;
- G. OSHA (29 CFR § 1910.269)

Article III – Inspection, Testing, Authorization, and Right to Access**3.1 Equipment Testing and Inspection.**

- A. Upon completing construction, the interconnection Customer shall test and inspect its generating facility including the interconnection equipment prior to interconnection in accordance with updated IEEE standards 1547 and IEEE standard 1547.1 by the City Electric Department. The interconnection Customer shall not operate its generating facility in parallel with distribution system without prior written authorization by the Utility.
- B. All interconnection related protective functions and associated direct current supplies shall be tested prior to commencement of commercial service, and (if nameplate rating of Customer's generating facilities is greater than 25 kW_{AC}) periodically tested thereafter no less than every three (3) years.

3.2 Certification of Completion. The interconnection Customer shall provide the Utility with a copy of the Certificate of Completion with all relevant and necessary information fully completed by the interconnection Customer, as well as an inspection form from the City Electric Department demonstrating that the generating facility passed inspection.**3.3 Witness Test.**

- A. The Utility shall perform a witness test after construction of the generating facility is completed but before parallel operation, unless the Utility specifically waives the witness test. The interconnection Customer shall provide the Utility at least 30 business days' notice of the planned commissioning test for the generating facility. If the Utility performs a witness test at a time that is not concurrent with the commissioning test, it shall contact the interconnection Customer to schedule the witness test at a mutually agreeable time within 10 business days after the commissioning test, the witness test is deemed waived unless the parties mutually agree to extend the date for scheduling the witness test, or unless the Utility cannot do so for good cause, in which case, the parties shall agree to another date for scheduling the test within 10 business days of the original scheduled date. For systems sized less than 25 kW_{AC} the 30 business days' notice shall be waived.
- B. If the witness test is not acceptable to the Utility, the interconnection Customer has 30 business days to address and resolve any deficiencies. This time period may be extended upon agreement between the Utility and interconnection Customer. If the interconnection Customer fails to address and resolve the deficiencies to the satisfaction of the Utility, this Agreement shall be terminated. The interconnection Customer shall, if requested by the Utility, provide a copy of all documentation in its possession regarding testing conducted pursuant to IEEE standard 1547.1.
- C. After the generating facility passes the witness testing, the Utility shall affix an authorized signature to the Certificate of Completion and return it to the interconnection Customer approving the interconnection and authorization parallel operation.

3.4 Right of Access. The Utility must have access to the disconnect switch and metering equipment of the generating facility at all times without notice. When practical, the Utility shall provide notice to the Customer prior to using its right of access.**Article IV – Effective Date, Term, Termination, and Disconnection****4.1 Effective Date.** This Agreement shall become effective upon execution by all parties.

Newton City Code

- 4.2 **Term of Agreement.** This Agreement shall become effective on the effective date and shall remain in effect unless terminated earlier in accordance with Article 4.4 of this Agreement.
- 4.3 **Governing Law, Regulatory Authority, and Rules.** The validity, interpretation and enforcement of this Agreement and each of its provisions shall be governed by the Codes and Regulations of the City as well as the laws of the State of Illinois without regard to its choice of law principals. Nothing in this Agreement is intended to affect any other agreement between the Utility and the interconnection Customer.
- 4.4 **Termination.** This Agreement may be terminated under the following conditions:
- A. By Interconnection Customer - the interconnection Customer may terminate this Agreement by providing written notice to the Utility. If the interconnection Customer ceases operation of the generating facility, the interconnection Customer must notify the Utility.
 - B. By the Utility - The Utility may terminate this Agreement if the interconnection Customer fails to remedy a violation of terms of this Agreement within 30 calendar days after notice, or such other date as may be mutually agreed to prior to the expiration of the 30-calendar day remedy period. The termination date may be no less than 30 calendar days after the interconnection Customer receives notice of its violation from the Utility.
 - C. Upon termination of this Agreement, the generating facility will be permanently disconnected from this distribution system. Terminating this Agreement does not relieve either party of its liabilities and obligations that are owed or continuing when the Agreement is terminated.
 - D. Upon termination of this Agreement, the Utility shall open and padlock the manual disconnect switch on Customer's premises.
- 4.5 **Disconnection.** The Utility may temporarily disconnect the generating facility upon any of the following conditions, but must reconnect the generating facility once the condition is cured:
- A. For scheduled outages, provided that the generating facility is treated in the same manner as Utility's load Customers;
 - B. For unscheduled outages or emergency conditions;
 - C. If the generating facility does not operate in the manner consistent with this Agreement;
 - D. Improper installation or failure to pass the witness test;
 - E. If the generating facility is creating a safety, reliability or a power quality problem; or
 - F. The interconnection equipment used by the generating facility is delisted by the nationally recognized testing Laboratory that provided the listing at the time the interconnection was approved.
 - G. Failure of the customer to obtain or maintain the insurance coverage set forth in Article 7 of this Agreement.
- 4.6 **Modification of Generating Facility.** The interconnection Customer must receive written authorization from the Utility before making any changes to the generating facility that could affect the distribution system. If the interconnection Customer makes such modifications without the Utility's prior written authorization, the Utility shall have the right to disconnect the generating facility immediately.
- 4.7 **Permanent Disconnection.** In the event the Agreement is terminated, the Utility shall have the right to disconnect its distribution system or direct the interconnection Customer to disconnect its generating facility.
- 4.8 **Lost Opportunity.** The Utility is not responsible for any lost opportunity or other costs incurred by the interconnection Customer as a result of an interruption of service under this Article 4.

Article V – Cost Responsibility for Interconnection Facilities and Distribution Upgrades

- 5.1 **Interconnection Facilities.**
- A. The interconnection Customer is responsible for the cost of additional interconnection facilities necessary to interconnect the generating facility with the distribution system.
 - B. The interconnection Customer is responsible for its expenses, including overheads, associated with owning, operation, maintaining, repairing, and replacing its interconnection equipment.

Newton City Code

- C. **Distribution System Upgrades.** The Utility shall design, procure, construct, install, and own any distribution system upgrades. The cost of the distribution system upgrades shall be directly assigned to the interconnection Customer whose generating facility caused the need for the distribution system upgrades.
- 5.2 **Cost for Small Systems.** For qualifying systems sized 10 kW_{AC} or less the cost in Section 5.1 shall be capped at \$1500.

Article VI – Assignment, Limitation on Damages, Indemnity, Force Majeure

- 6.1 **Assignment/Transfer of Ownership of the Generating Facility.** This Agreement shall terminate upon the transfer of ownership of the generating facility to a new owner unless the transferring owner assigns the Agreement to the new owner, the new owner agrees in writing to the terms of this Agreement, and the transferring owner so notifies the Utility in writing prior to the transfer of ownership.
- 6.2 **Limitation of Liability.** Each party's liability to the other Party for any loss, cost, claim, injury, liability, or expense, including reasonable attorney's fees, relating to or arising from any act or omission in its performance of this Agreement, shall be limited to the amount of direct damage actually incurred. In no event shall either Party be liable to the amount of direct damage actually incurred. In no event shall either Party be liable to the other Party for any indirect, incidental, special, consequential, or punitive damages of any kind whatsoever.
- 6.3 **Indemnification.** The interconnection Customer shall indemnify and defend the City, Utility, and the elected officials, directors, officers, employees, and agents from all damages and expenses resulting from any third party claim arising out of or based upon the interconnection Customer's (a) negligence or willful misconduct; (b) breach of this Agreement; or (c) the operation of the Customer's generating facility, regardless of Customer's negligence or willful misconduct, except when and to the extent the loss occurs due to the grossly negligent actions of the Utility. The Utility shall indemnify and defend the interconnection Customer and the interconnection Customer's directors, officers, employees, and agents from all damages and expenses resulting from a third-party claim arising out of or based upon the Utility's (a) negligence or willful misconduct or (b) breach of this Agreement.
- 6.4 **Force Majeure.** If a force majeure event prevents a Party from fulfilling any obligations under this Agreement, the party affected by the force majeure event (Affected Party) shall notify the other Party of the existence of the force majeure event within one business day. The notification must specify the circumstances of the force majeure event, the expected duration, and the steps that the Affected Party is taking and will take to mitigate the effects of the event on its performance. If the initial notification is verbal, it must be followed up with a written notification within one business day. The Affected Party shall keep the other Party informed on a continuing basis of developments relating to the force majeure event until the event ends. The Affected Party may suspend or modify its obligations under this Agreement. The term "force majeure" shall mean any act of God, labor disturbance, act of the public enemy, war, insurrection, riot, fire, storm or flood, explosion, epidemic, pandemic, breakage or accident to machinery or equipment, an order, regulation or restriction imposed by governmental, military or lawfully established civilian authorities, or any other cause beyond a Party's reasonable control. A Force Majeure event does not include an act of negligence or intentional wrongdoing by the party claiming Force Majeure.

Article VII – Insurance

- 7.1 **Insurance.** The interconnection customer shall carry general liability insurance coverage, such as, but not limited to, homeowner's insurance or commercial building insurance. The interconnection Customer shall provide the Utility with proof that it has a current homeowner's insurance or commercial building insurance policy, or other general liability policy. The interconnection Customer shall name the Utility as an additional insured on its homeowner's insurance or commercial building insurance policy, or similar policy covering general liability and shall cause the insurance company to issue a Certificate of Insurance to the Utility. The

Newton City Code

interconnection customer shall notify the Utility immediately if such insurance policy is terminated or cancelled prior to the end of its term and if the insurance company has communicated an intent not to renew the policy.

Article VIII – Documents and Notices

- 8.1 **Documents.** The Agreement includes the following documents, which are attached and incorporated by reference:
 - A. One-line drawing
 - B. Interconnection Request Application Form
 - C. System Upgrade Estimated Costs
 - D. Certificate of Completion

8.2 **Notice.** The Parties may mutually agree to provide notices, demands, comments, or requests by electronic means such as e-mail. Absent Agreement to electronic communication, or unless otherwise provided in this Agreement, any written notice, demand, or request required or authorized in connection with this Agreement shall be deemed properly given if delivered in person, delivered by recognized national courier service, or sent by first class mail, postage prepaid, to the person specified below:

If to Interconnection Customer:

Use the contact information provided in the interconnection Customer’s application. The interconnection customer is responsible for notifying the Utility of any change in the contact party information, including change of ownership.

If to Utility:

Use the contact information provided below. The Utility is responsible for notifying the interconnection Customer of any change in the contact party information.

Name: _____

Mailing Address: _____

City: _____ State: _____ Zip Code: _____

Telephone (Daytime): _____ (Evening) _____

Fax Number: _____ Email Address: _____

Article IX – Signatures

IN WITNESS WHEREOF, the Parties have caused this Agreement to be executed by their respective duly authorized representatives.

Newton City Code

EXHIBIT "C"

Sample One-line Interconnection Diagram

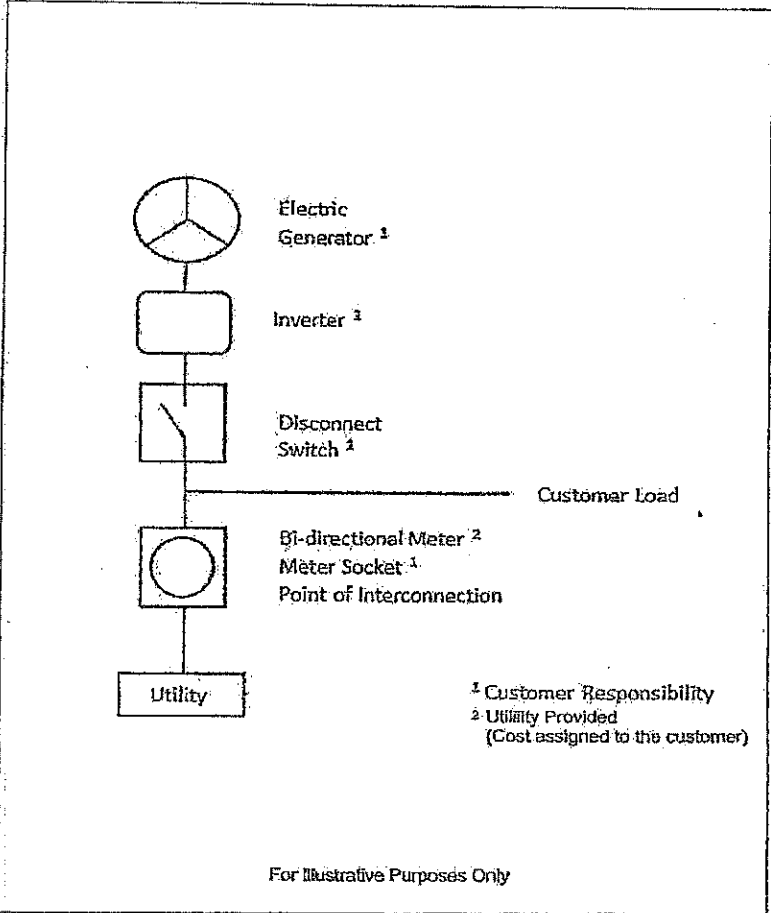

Newton City Code

EXHIBIT "D"

City of Newton Standard Distributed Generation Interconnection Request Application Form (Lab-Certified) Inverter-Based Distributed Generation Facilities 25 kW and Smaller

Interconnection Applicant Contact Information

Customer Name: _____
 Primary Contact: _____
 Mailing Address: _____
 City: _____ State: _____ Zip Code: _____
 Telephone (Daytime): _____ (Evening): _____
 Fax Number: _____ Email Address: _____

Additional Contact Information (if different from primary contact)

Name: _____
 Mailing Address: _____
 City: _____ State: _____ Zip Code: _____
 Telephone (Daytime): _____ (Evening): _____
 Fax Number: _____ Email Address: _____

Equipment Contractor

Name: _____
 Mailing Address: _____
 City: _____ State: _____ Zip Code: _____
 Telephone (Daytime): _____ (Evening): _____
 Fax Number: _____ Email Address: _____

Electrical Contractor (if different from Equipment Contractor)

Name: _____
 Mailing Address: _____
 City: _____ State: _____ Zip Code: _____
 Telephone (Daytime): _____ (Evening): _____
 Fax Number: _____ Email Address: _____
 Contractor License Number: _____

Active License? Yes No

Registered with Municipality? Yes No

Is the Interconnection Customer requesting Net Metering? Yes No

Newton City Code

Distributed Generation Facility ("Facility") Information

Facility Address: _____

City: _____ State: _____ Zip Code: _____

City of Newton serving Facility site: _____

Account Number of Facility site: _____

Inverter Manufacturer: _____ Model: _____

Is the inverter lab-certified as that term is defined in the Illinois Distributed Generation Interconnection Standard? Yes No

(If yes, attach manufacturer's technical specifications and label information from a nationally recognized testing laboratory.)

Generation Facility Nameplate Rating: ___ (kW) _____ (kVA) _____ (AC Volts)

Prime Mover: Photovoltaic Turbine

Energy Source: Solar Wind

In-Service Date: _____

(If the In-Service Date changes, the interconnection customer must inform the utility as soon as it is aware of the changed date.)

Insurance Disclosure

The attached terms and conditions contain provisions related to liability and indemnification and should be carefully considered by the interconnection customer. The interconnection customer shall carry general liability insurance coverage, such as, but not limited to, homeowner's insurance. Whenever possible, the interconnection customer shall name the City as an additional insured on its homeowner's insurance policy, or similar policy covering general liability.

Customer Signature

I hereby certify that: (1) I have read and understand the terms and conditions which are attached hereto by reference; (2) I hereby agree to comply with the attached terms and conditions; and (3) to the best of my knowledge, all of the information provided in this application request form is complete and true.

Applicant Signature: _____ Date: _____

Name: _____ Title: _____

Conditional Agreement to Interconnect Distributed Generation Facility

By its signature below, the (utility) has determined the interconnection request is complete. Interconnection of the distributed generation facility is conditionally approved contingent upon the attached terms and conditions of this Agreement, the return of the attached Certificate of Completion, duly executed verification of electrical inspection and successful witness test.

Utility Representative Signature: _____ Date: _____

Name: _____ Title: _____

Newton City Code

EXHIBIT "E"

**City of Newton Standard Distributed Generation
Interconnection Request Application Form (Lab-Certified)
Inverter-Based Distributed Generation Facilities (Greater than 25 kW – 1MW)**

Interconnection Applicant Contact Information

Customer Name: _____
Primary Contact: _____
Mailing Address: _____
City: _____ State: _____ Zip Code: _____
Telephone (Daytime): _____ (Evening): _____
Fax Number: _____ Email Address: _____

Alternative Contact Information (if different from Primary Contact Information)

Name: _____
Mailing Address: _____
City: _____ State: _____ Zip Code: _____
Telephone (Daytime): _____ (Evening): _____
Fax Number: _____ Email Address: _____
Facility Address (if different from above): _____
City: _____ State: _____ Zip Code: _____
City of Newton serving Facility site: _____
Account Number of Facility site (existing utility customers): _____
Inverter Manufacturer: _____ Model: _____

Equipment Contractor

Name: _____
Mailing Address: _____
City: _____ State: _____ Zip Code: _____
Telephone (Daytime): _____ (Evening): _____
Fax Number: _____ Email Address: _____

Electrical Contractor (if different from Equipment Contractor)

Name: _____
Mailing Address: _____
City: _____ State: _____ Zip Code: _____
Telephone (Daytime): _____ (Evening): _____

Newton City Code

Fax Number: _____ Email Address: _____

License Number: _____

Electric Service Information for Customer Facility Where Generator Will Be Interconnected

Capacity: _____ (Amps) Voltage: _____ (Volts)

Type of Service: Single Phase Three Phase

If 3 Phase Transformer, Indicate Type:

Primary	Winding	Wye	Delta
Secondary	Winding	Wye	Delta

Transformer Size: _____ Impedance: _____

Intent of Generation

Offset Load (Unit will operate in parallel, but will not export power to utility)

Net Meter (Unit will operate in parallel and will occasionally export power into the distribution system)

Generator & Prime Mover Information

ENERGY SOURCE (Wind and Solar): _____		
ENERGY CONVERTER TYPE (Wind Turbine, Photovoltaic Cell): _____		
GENERATOR SIZE: kW or kVA	NUMBER OF UNITS: _____	TOTAL CAPACITY: kW or kVA
GENERATOR TYPE (Check one):		
Induction Inverter	Synchronous	Other

Distributed Generation Facility Information

In-Service Date: _____

List interconnection components/systems to be used in the distributed generation facility that are lab-certified.

Component/System	NRTL Providing Label & Listing
1. _____	_____
2. _____	_____
3. _____	_____
4. _____	_____
5. _____	_____

Please provide copies of manufacturer brochures or technical specifications.

Newton City Code**Energy Production Equipment/Inverter Information:**

Synchronous Induction Inverter _____ Other _____

Rating: _____ kW Rating: _____ kVA

Rated Voltage: _____ Volts

Rated Current: _____ Amps

System Type Tested (Total System):

Yes No attach product literature

Additional Information for Inverter-Based Facilities

Inverter Information:

Manufacturer: _____ Model: _____

Type: Forced Commutated _____ Line Commutated _____

Rated Output: _____ Watts _____ Volts

Efficiency: _____ % Power Factor: _____ %

Inverter UL 1741 Listed: Yes No

DC Source/Prime Mover

Rating: _____ kW Rating: _____ kVA

Rated Voltage: _____ Volts

Open Circuit Voltage (if applicable): _____ Volts

Rated Current: _____ Amps

Short Circuit Current (if applicable): _____ Amps

Other Facility Information

One Line Diagram attached: Yes

Plot Plan attached: Yes

Insurance Disclosure

The attached terms and conditions contain provisions related to liability and indemnification, and should be carefully considered by the interconnection customer. The interconnection customer shall carry general liability insurance coverage, such as, but not limited to, homeowner's insurance. Whenever possible, the interconnection customer shall name the City as an additional insured on its homeowner's insurance policy, or similar policy covering general liability.

Customer Signature

I hereby certify that all of the information provided in this Interconnection Request Application Form is true.

Newton City Code

Applicant Signature: _____

Printed Name: _____ Title: _____

Title: _____ Date: _____

Utility Acknowledgement

Receipt of the application fee is acknowledged and this interconnection request is complete.

Utility Signature: _____ Date: _____

Printed Name: _____ Title: _____

Newton City Code**EXHIBIT "F"****Certificate of Completion**

To be completed and returned to City Hall when installation is complete and final electric inspector approval has been obtained*

Interconnection Customer Information

Customer Name: _____
 Primary Contact: _____
 Mailing Address: _____
 City: _____ State: _____ Zip Code: _____
 Telephone (Daytime): _____ (Evening): _____
 Fax Number: _____ Email Address: _____

Installer Check if owner-installed

Name: _____
 Mailing Address: _____
 City: _____ State: _____ Zip Code: _____
 Telephone (Daytime): _____ (Evening): _____
 Fax Number: _____ Email Address: _____

Final Electric Inspection and Interconnection Customer Signature

The distributed generation facility is complete and has been approved by the local electric inspector having jurisdiction. A signed copy of the electric inspector's form indicating final approval is attached. The interconnection customer acknowledges that it shall not operate the distributed generation facility until receipt of the final acceptance and approval by the utility as provided below.

Signed: _____ Date: _____
(Signature of interconnection customer)

Printed Name: _____

Check if copy of signed electric inspection form is attached

Check if copy of as built documents is attached (projects larger than 10 kVA only)

Acceptance and Final Approval for Interconnection (for utility use only)

The interconnection agreement is approved, and the distributed generation facility is approved for interconnected operation upon the signing and return of this Certificate of Completion by utility:

Utility waives Witness Test? (Initial) Yes (___) No (___)

If not waived, date of successful Witness Test: _____ Passed: (Initial) _____

Utility Signature: _____ Date: _____

Printed Name: _____ Title: _____

* Prior to interconnected operation, the interconnection customer is required to complete this form and return it to the utility.

EXHIBIT "B"

ARTICLE III - TREES AND SHRUBS

33-3-1 **PLANTING.** It shall be unlawful to plant any tree or bush in any public street or parkway or other public place without having first secured a permit, therefore. Applications for such permits shall be made to the Street Superintendent and shall be referred by him to the City Council. All trees and shrubs so planted shall be placed subject to the directions and approval of the City Council.

33-3-2 **PLANTING TREES IN RIGHT-OF-WAY.** It shall be unlawful to plant any bushes, trees, shrubs or other plants on the right-of-way of any public street, including the space on the right-of-way between the sidewalk and the adjacent street pavement.

33-3-3 **REMOVAL.** It shall be unlawful to remove or cut down any tree or shrub or portion thereof in any street, parkway or other public place without having first secured a permit, therefore. Applications for such permits shall be made to the Street Superintendent and shall be referred by him to the City Council before permission shall be granted.

33-3-4 **INJURY.** It shall be unlawful to injure any tree or shrub planted in such public place.

33-3-5 **ADVERTISEMENTS OR NOTICES.** It shall be unlawful to attach any sign, advertisement or notice to any tree or shrub in any street, parkway, or other public place.

33-3-6 **DANGEROUS TREES.** Any tree or shrub which overhangs any sidewalk, street or other public place in the municipality at a height less than **eight (8) feet** or in such a way as to impede or interfere with traffic or travel on such public place shall be trimmed by the owner of the abutting premises or of the premises on which such tree or shrub grows so that the obstruction shall cease. Any tree or limb of a tree which has become likely to fall on or across any public way or place, or if it is deemed to in any way provide a potential safety hazard to the public or City property shall be removed by the owner of the premises on which such tree grows or stands. The Street Superintendent may, at the owner's expense, trim or remove any tree or shrub so that the obstruction or danger to traffic or passage shall be done away with.

33-3-7 **WIRES.** It shall be unlawful to attach any wires or rope to any tree or shrub in any public street, parkway or other public place without the permission of the City Council. Any person or company given the right to maintain the poles and wires in the streets, alleys, or other public places in the municipality shall, in the absence of provision in the franchise concerning the subject, keep such wires and poles free from and away from any trees or shrubs in such places so far as may be possible and shall keep all such trees and shrubs properly trimmed, subject to the supervision of the Street Superintendent so that no injury shall be done either to the poles or wires or the shrubs and trees by their conduct.

33-3-8 **GAS PIPES.** Any person or company maintaining any gas pipe in the municipality shall, in the absence of provision in the franchise concerning the subject, keep such pipes free from leaks so that no injury shall be done to any trees or shrubs.

33-4-17

VEGETATION CONTROL.

(A) **Electric Utilities - Compliance with State Laws and Regulations.** An electric utility shall conduct all tree-trimming and vegetation control activities in the right-of-way in accordance with applicable Illinois laws and regulations, and additionally, with such local franchise or other agreement with the City as permitted by law.

- (1) **Tree Removal and Trimming.** The City reserves the right to trim or remove any tree which creates a line-clearance hazard as defined by the National Electrical Safety Code (NESC), or if it is deemed to in any way to impair that supplier's ability to provide safe and reliable service and unsafe working condition for the City or any other utility.